

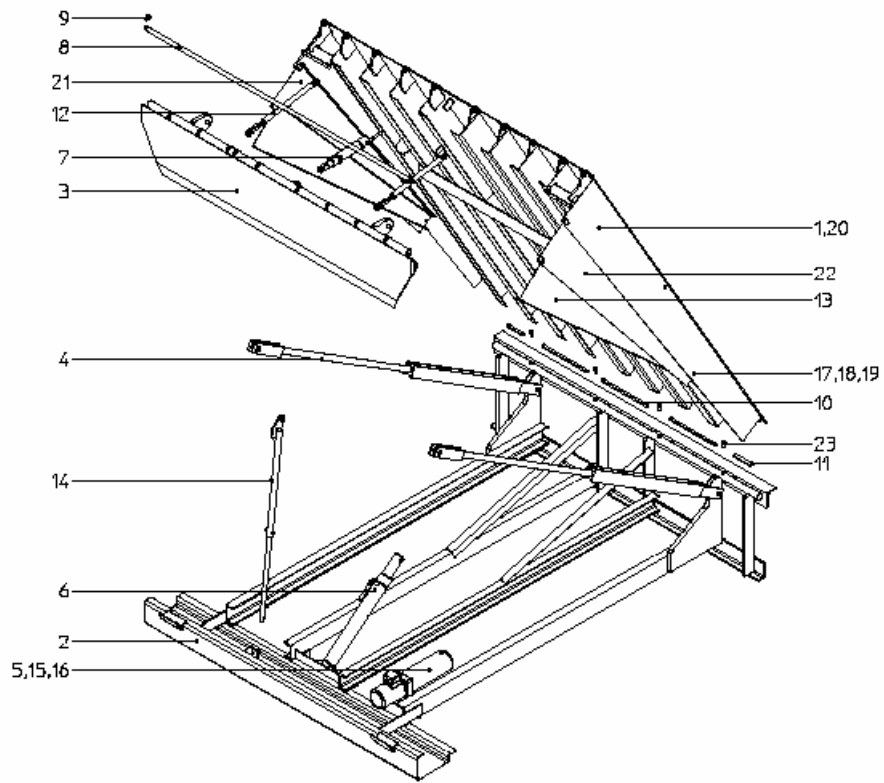

## Dock Leveller HWP Model

### Spare Parts List



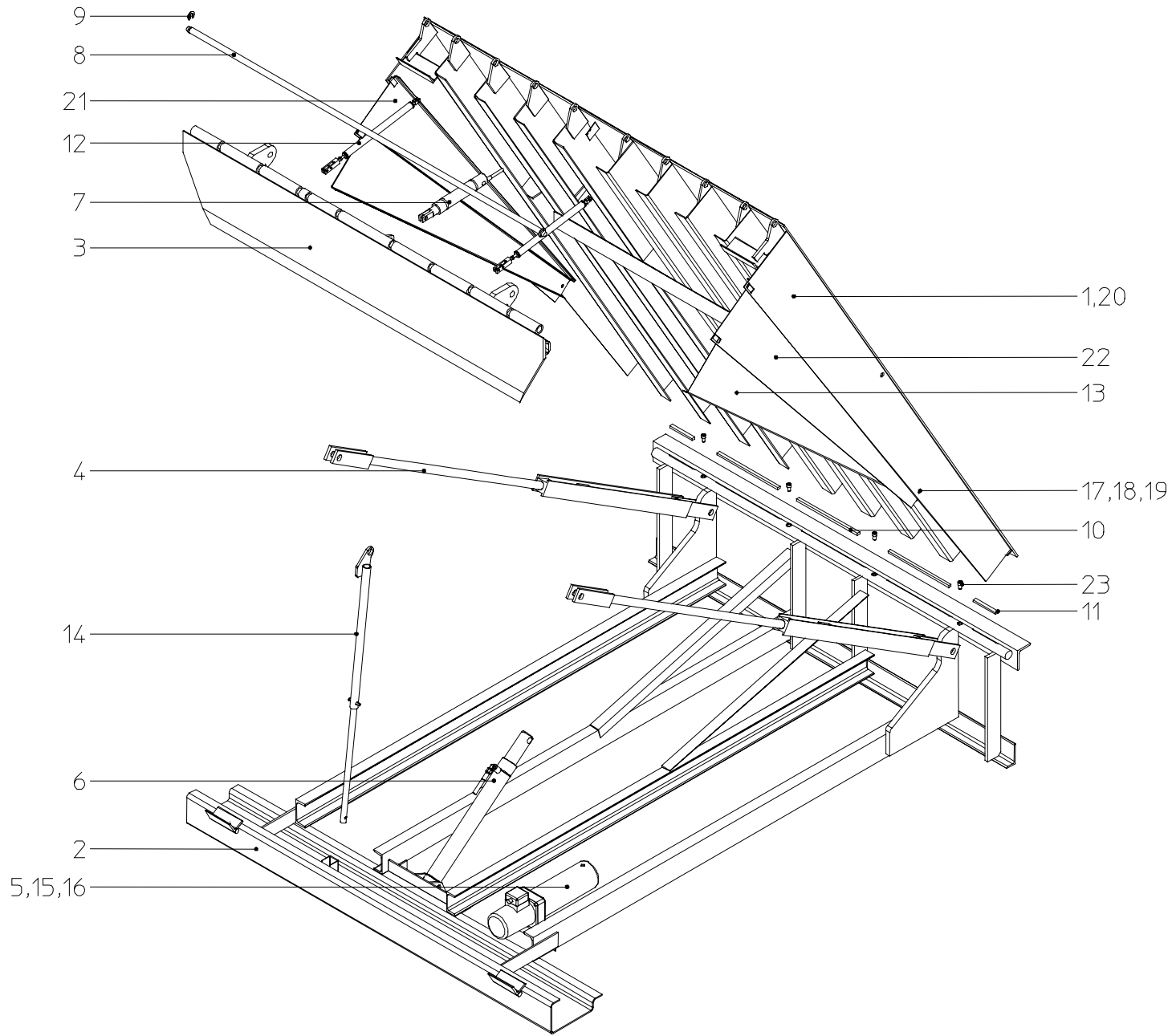
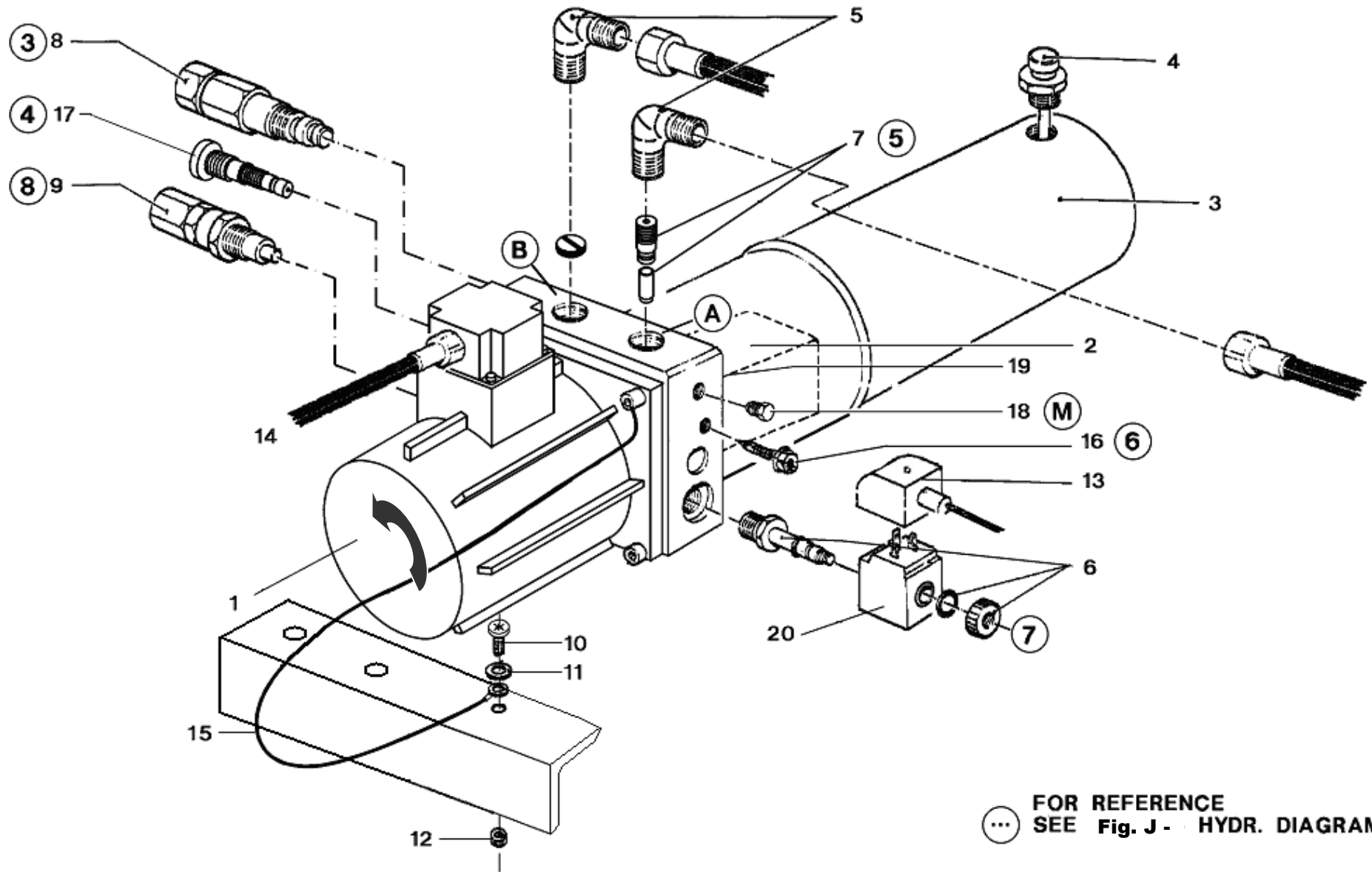

FIG. A PARTS SUBFRAME, DECK AND LIP

INDEX	DESCRIPTION	REFERENCE			
		HWP 608	HWP 708	HWP 600	HWP 700
1	Deck	04.730.100	04.740.100	04.750.100	04.760.100
2	Subframe	04.730.200	04.740.200	04.750.200	04.760.200
3	Lip	04.730.300	04.740.300	04.750.300	04.760.300
4	Pull bar	See Fig. F			
5	Hydraulic unit	See Fig. B			
6	Main cylinder	See Fig. C			
7	Lip cylinder	See Fig. D			
8	Lip rod	04.730.001	04.630.001	04.730.001	04.630.001
9	Retaining ring	65.062.036	65.062.036	65.062.036	65.062.036
10	Shock absorbing strip (3x)	04.630.009	04.630.009	04.630.009	04.630.009
11	Shock absorbing strip (2x)	-	04.655.008	-	04.655.008
12	Gas tension spring	See Fig. E			
13	Toe protector	04.730.002	04.730.002	04.750.002	04.750.002
14	Maintenance strut	04.630.025	04.630.025	04.635.025	04.635.025
15	Bolt	65.003.403	65.003.403	65.003.403	65.003.403
16	Spring washer	65.058.028	65.058.028	65.058.028	65.058.028
17	Bolt	65.025.014	65.025.014	65.025.014	65.025.014
18	Washer	65.055.712	65.055.712	65.055.712	65.055.712
19	Nut	65.051.034	65.051.034	65.051.034	65.051.034
20	Yellow/black marking	90.899.024	90.899.024	90.899.024	90.899.024
21	Sliding lamel Left	-	-	04.750.010	04.750.010
22	Sliding lamel Right	-	-	04.750.011	04.750.011
23	Bolt	65.012.443	65.012.443	65.012.443	65.012.443



INDEX	REFERENCE	DESCRIPTION
	02.335.630	Motorpumpunit assembly (excl. fittings)
1	02.335.611	Electro-motor
2	02.335.612	Pump + coupling
3	02.335.613	Tank
4	02.335.614	Cap with dip-stick
5	01.810.502	Adaptor
6	68.308.002	Stop valve incl. coil
7	02.335.636	Special valve
8	02.335.637	Sequence valve
9	02.335.618	Overflow valve
10	65.034.222	Bolt
11	1038.27.00.43	Washer
12	65.050.124	Nut
13	02.210.021	Electric cable assembly
14	01.810.763	Cable
15	02.335.602	Earth cable
16	02.335.639	Throttle
17	02.335.640	Special valve
18	02.335.621	Plug
19	02.335.622	O-ring tank
20	69.481.501	Coil

**FIG. C MAIN CYLINDER**

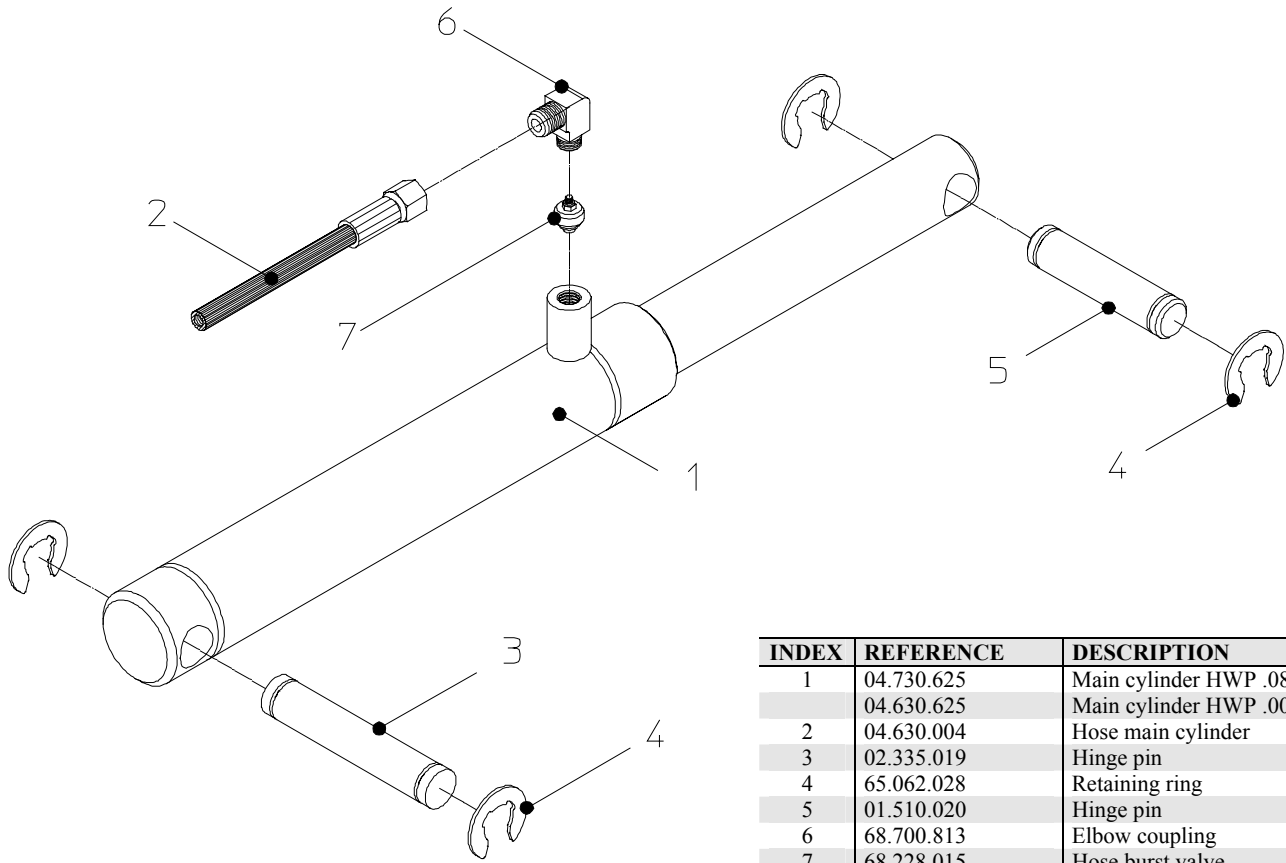

INDEX	REFERENCE	DESCRIPTION
1	04.730.625	Main cylinder HWP .08 *)
	04.630.625	Main cylinder HWP .00 *)
2	04.630.004	Hose main cylinder
3	02.335.019	Hinge pin
4	65.062.028	Retaining ring
5	01.510.020	Hinge pin
6	68.700.813	Elbow coupling
7	68.228.015	Hose burst valve

\*) Incl. index 6 & 7

**FIG. D LIP CYLINDER**

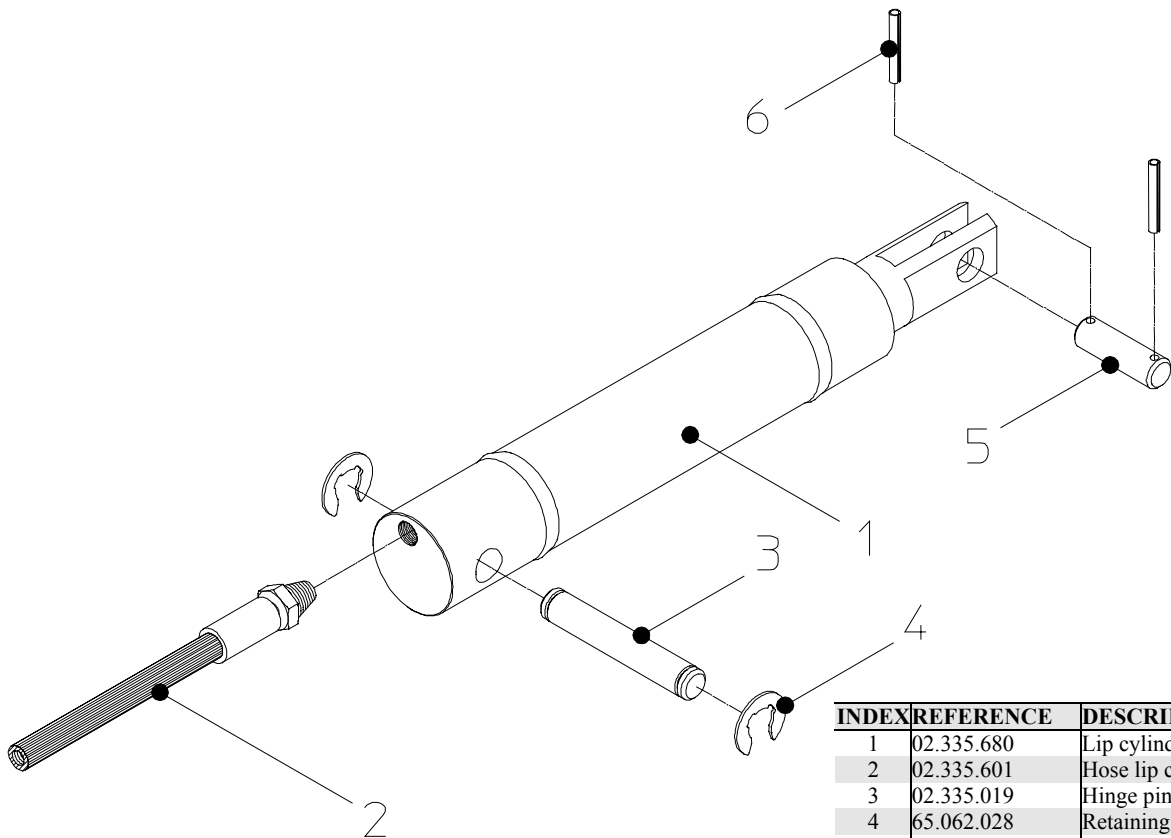

INDEX	REFERENCE	DESCRIPTION
1	02.335.680	Lip cylinder
2	02.335.601	Hose lip cylinder
3	02.335.019	Hinge pin
4	65.062.028	Retaining ring
5	01.510.020	Hinge pin
6	65.077.101	Spring pin

**FIG. E TENSION GAS SPRING**

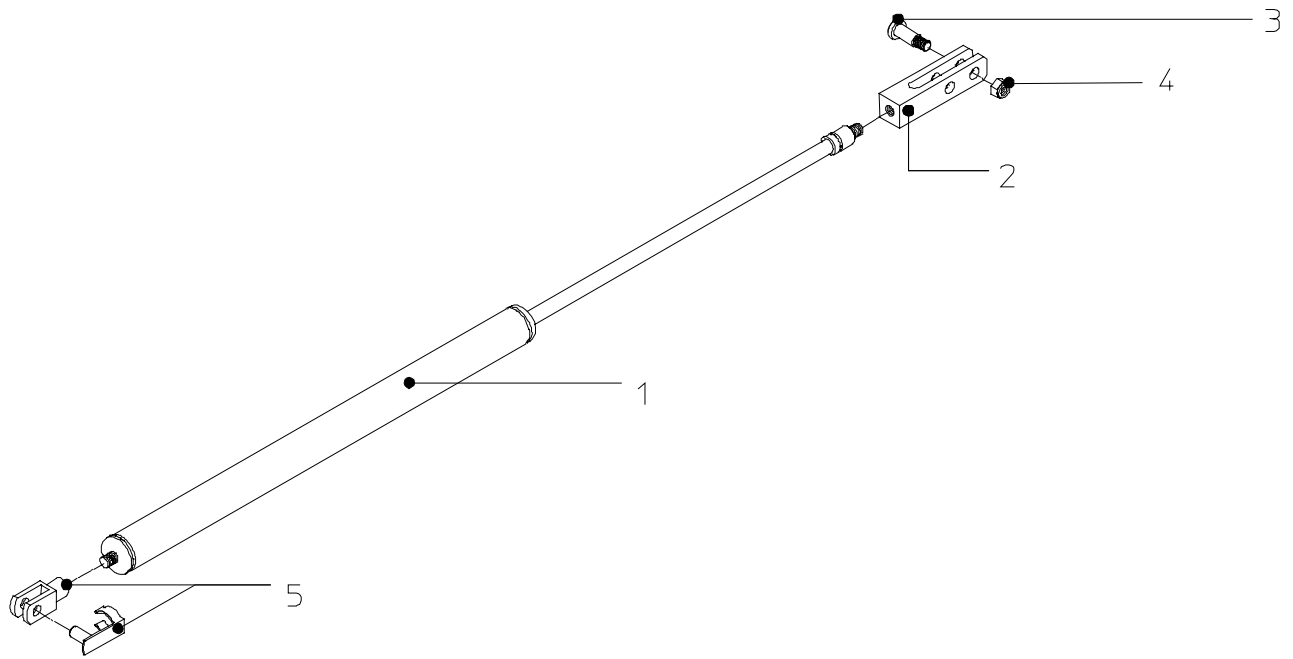

INDEX	REFERENCE	DESCRIPTION
1	04.630.077	Gas spring
2	04.630.076	Clevis
3	65.025.101	Bolt with shoulder
4	65.051.032	Self locking nut
5	60.203.003	Clevis with pin

**FIG. F PULL BAR**

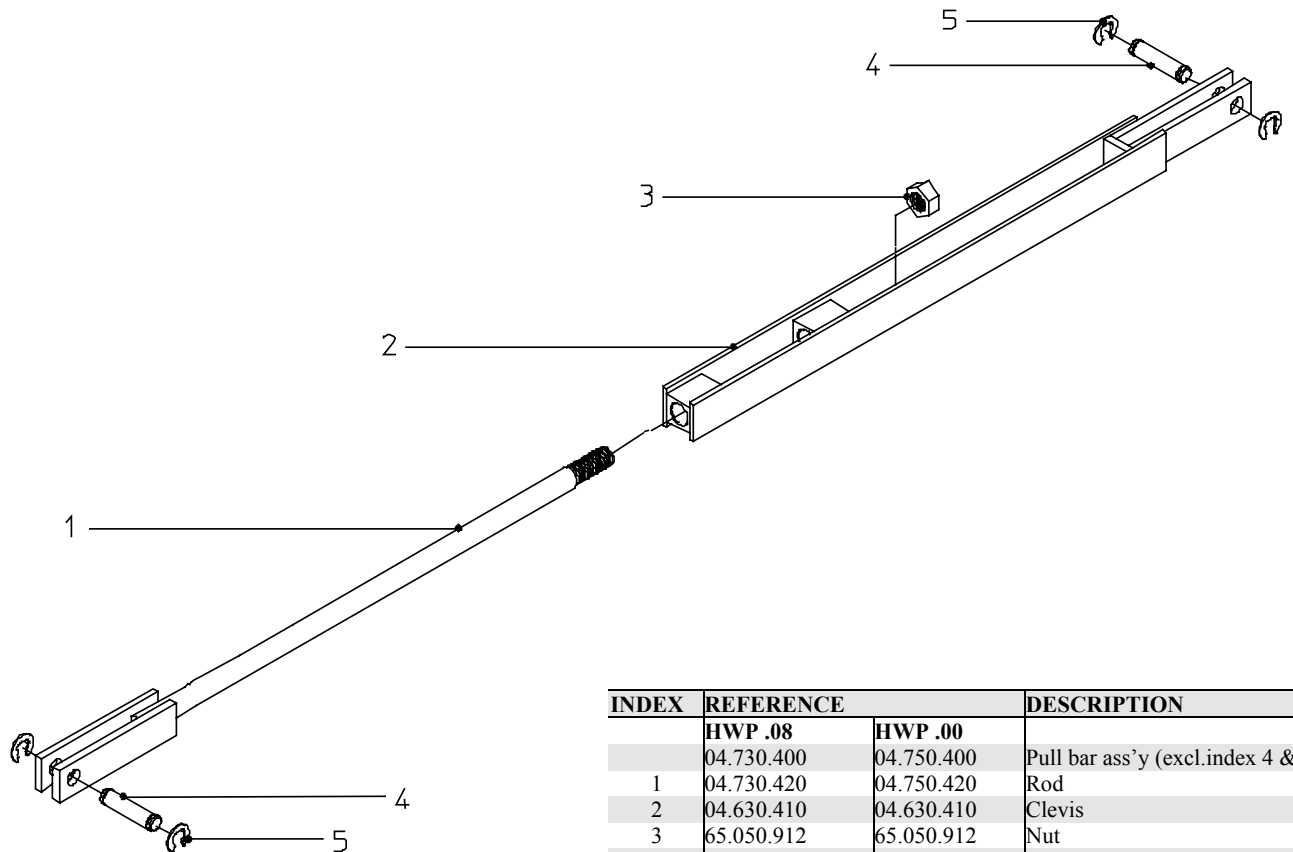

INDEX	REFERENCE		DESCRIPTION
	HWP .08	HWP .00	
	04.730.400	04.750.400	Pull bar ass'y (excl.index 4 & 5)
1	04.730.420	04.750.420	Rod
2	04.630.410	04.630.410	Clevis
3	65.050.912	65.050.912	Nut
4	02.210.019	02.210.019	Hinge pin
5	65.062.036	65.062.036	Retaining ring

**FIG. G CONTROL BOX**

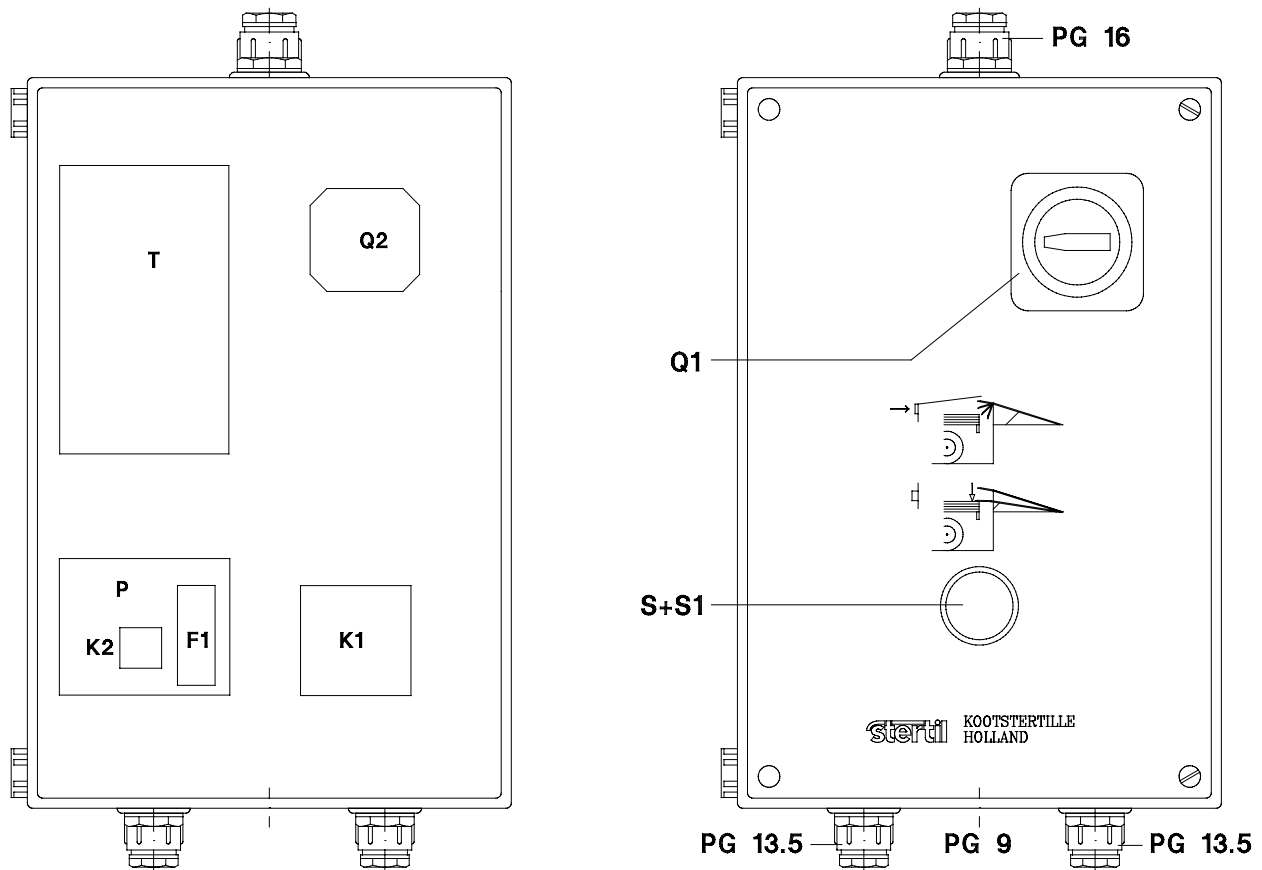

REFERENCE		DESCRIPTION			
	02.210.755	Bedieningskast 400V	Bedienungskaste 400V	Control box 400V	Coffre de commande 400V
	02.219.755 Option	Bedieningskast 230V	Bedienungskaste 230V	Control box 230V	Coffre de commande 230V
Q	69.120.004	Hoofdschakelaar compleet	Hauptschalter Komplett	Main switch complete	Interrupteur principal complète
Q1	69.120.005	Knopdeel	Knopfteil	Buttonpart	Partie interrupteur à poussoir
Q2	69.120.006	Schakeldeel	Schalterteil	Switchpart	Partie interrupteur
K1	01.615.652	Magneetschakelaar	Magnetschalter	Magnetic switch	Interrupteur magnetique
P	69.900.120	Printplaat	Leiterplatte	Printed circuitboard	Circuit imprimé
F1	69.206.006	Zekering 250mA traag	Sicherung 250mA trag	Fuse 250mA slow	Fusible 250mA lent
	69.206.007 Option	Zekering 400mA traag	Sicherung 400mA trag	Fuse 400mA slow	Fusible 400mA lent
T	69.500.005	Transformator 400V	Transformator 400V	Transformer 400V	Transformateur 400V
	69.500.006 Option	Transformator 230V	Transformator 230V	Transformer 230V	Transformateur 230V
K2	Zie P	Realais 24V	Realais 24V	Realais 24V	Realais 24V
S	69.141.014	Drukknopschakelaar	Druckknopfschalter	Pushbutton switch	Interrupteur à poussoir
S1	69.141.013	Drukknop	Druckknopf	Pushbutton	Interrupteur à poussoir



**FIG. H CONTROLBOX WITH DOORSWITCH (OPTION)**

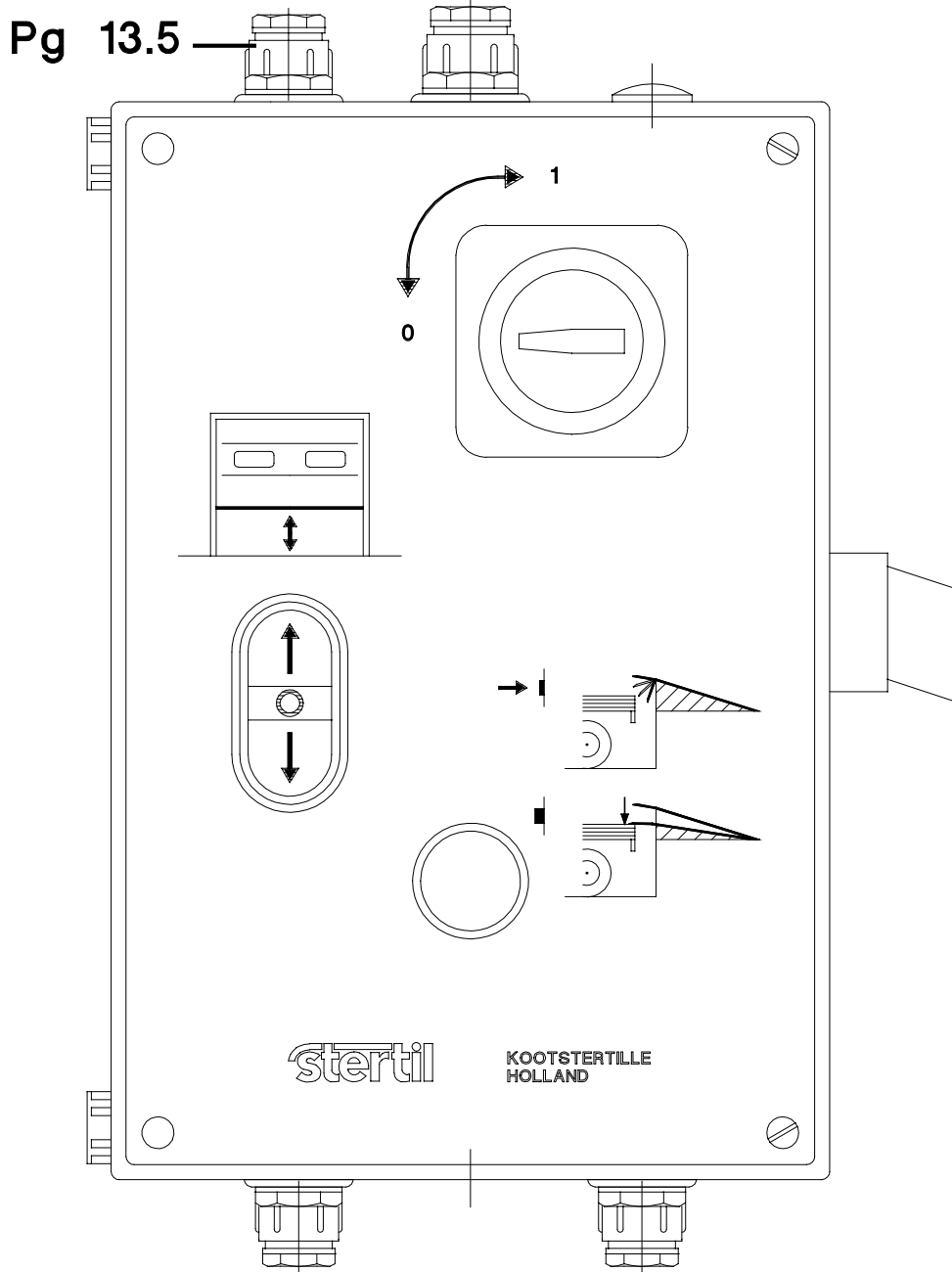

REFERENCE		DESCRIPTION			
	02.219.780	Bedieningskast + DS 400V	Bedienungskaste + DS 400V	Control box + DS 400V	Coffre de commande + DS 400V
	02.219.785	Bedieningskast + DS 230V	Bedienungskaste + DS 230V	Control box + DS 230V	Coffre de commande + DS 230V
	02.219.790	Bed. kast + BDC + DS 400V	Bed. kaste + BDC + DS 400V	Control box + BDC + DS 400V	Coffre de comm. + BDC + DS 400V
	02.219.795	Bed. kast + BDC + DS 230V	Bed. kaste + BDC + DS 230V	Control box + BDC + DS 230V	Coffre de comm. + BDC + DS 230V
SD	69.141.036	Deurschakelaar compleet	Türschalter komplett	Door switch complete	Interrupteur de porte complet
SD1	69.141.037	NO kontaktblok	NO Kontaktblock	NO Contact block	Bloc de contact NO
SD2	69.141.038	NC kontaktblok	NC Kontaktblock	NC Contact block	Bloc de contact NC