

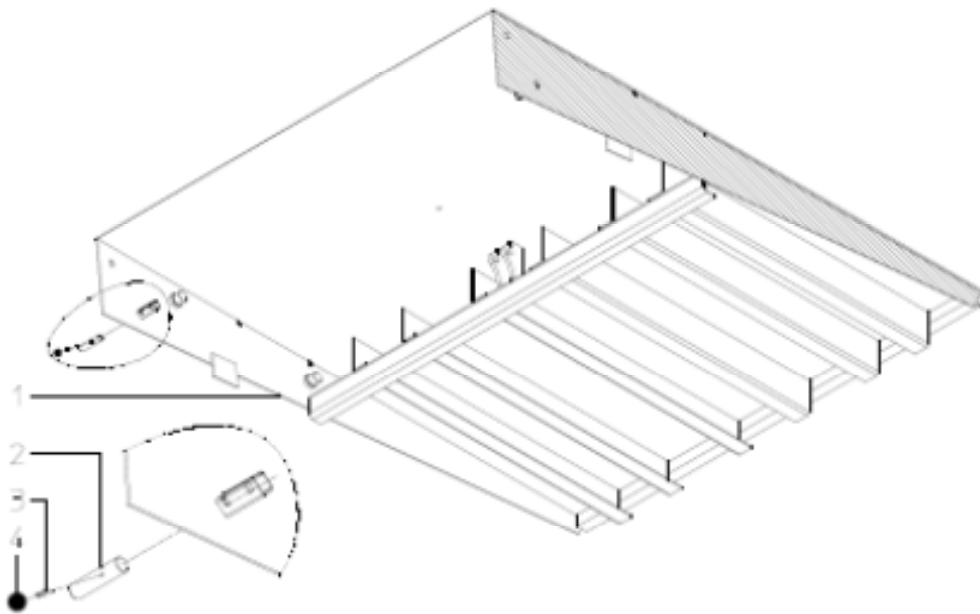

## Dock Leveller XP Model

### Spare Parts List



**Fig. A Deck**

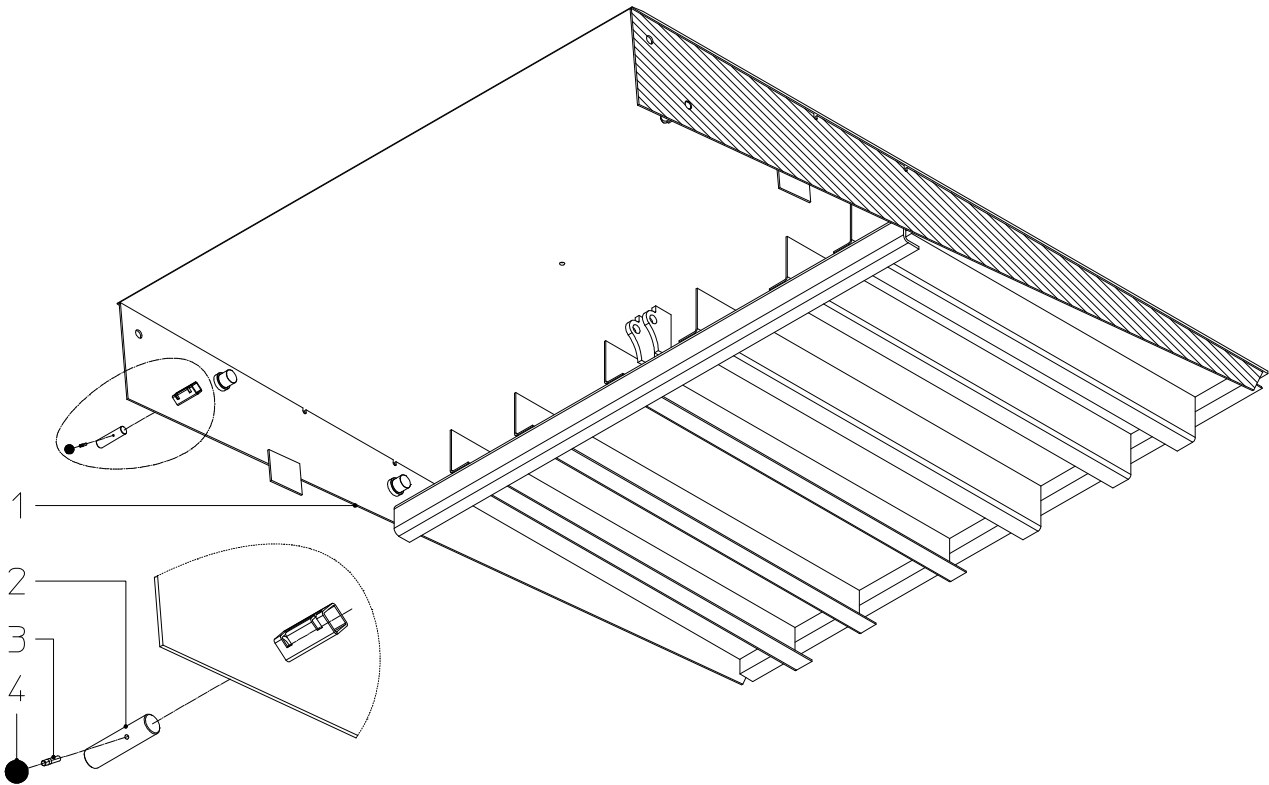

**Table A-1 Decks (1) (thread plate)**

Width/Length	XP 20..	XP 22..	XP 25..	XP 28..	XP 30..	XP 35..	XP 40..	XP 45..
XP ..17	06200100	06210100	06220100	06230100	06240100	06250100	06260100	06270100
XP ..18	06202100	06212100	06222100	06232100	06242100	06252100	06262100	06272100
XP ..20	06204100	06214100	06224100	06234100	06244100	06254100	06264100	06274100
XP ..21	06206100	06216100	06226100	06236100	06246100	06256100	06266100	06276100
XP ..22	06208100	06218100	06228100	06238100	06248100	06258100	06268100	06278100

**Table A-2 Additional parts**

Index	Reference	Description
2	02400003	Maintenance pin
3	65025055	Stud bolt
4	1005.11.00.03	Ball knob

**Fig. B Frame**

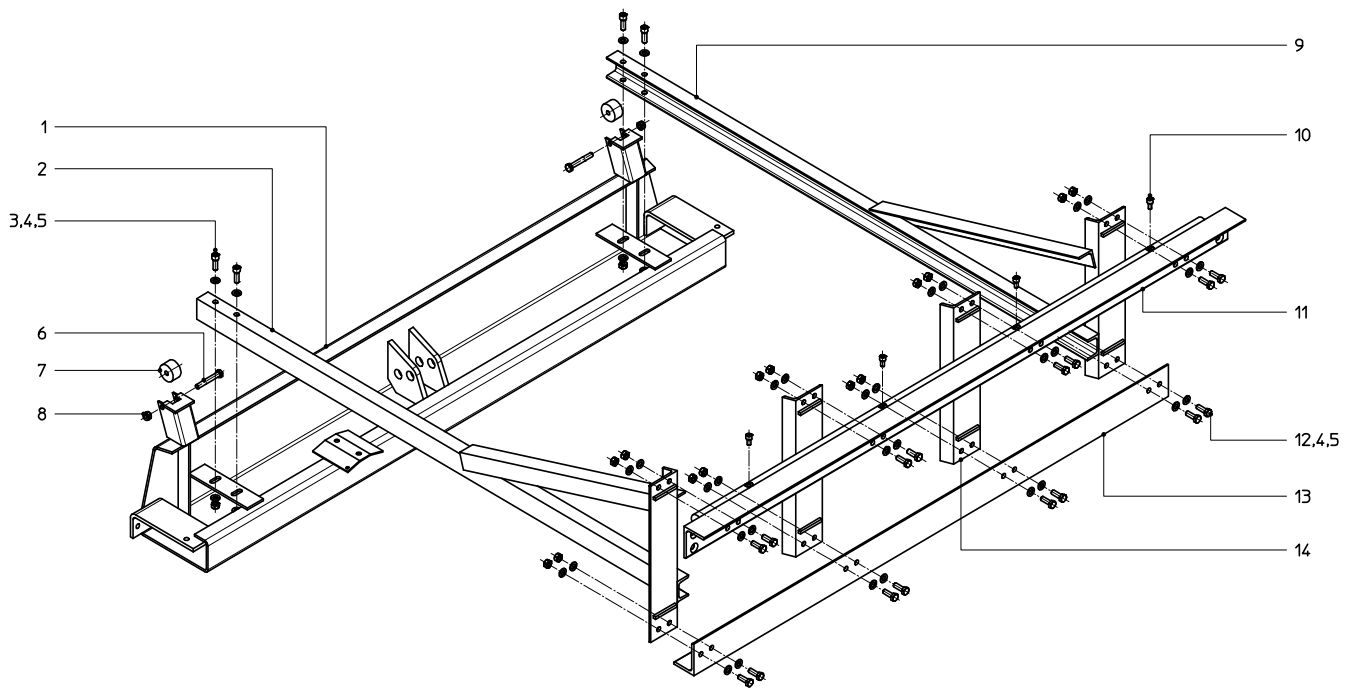

**Table B-1 Subframe beams**

	XP 20..	XP 22..	XP 25..	XP 28..	XP 30..	XP 35..	XP 40..	XP 45..
Side beam Left (9)	06100210	06110210	06120210	06130210	06140210	06150210	06160210	06170210
Side beam Right (2)	06100215	06110215	06120215	06130215	06140215	06150215	06160215	06170215
Vert. support (14)	06100240	06100240	06100240	06100240	06100240	06150240	06150240	06150240

**Table B-2 Subframe parts**

	Front angle (1)	Rear support (13)	Rear hinge (11)
XP ..17	06000220	06100230	06100225
XP ..18	06002220	06100230	06102225
XP ..20	06004220	06100230	06104225
XP ..21	06006220	06100230	06106225
XP ..22	06008220	06100230	06108225

**Table B-3 Additional parts**

Index	Reference	Description
3	65012448	Socket head screw
4	65055021	Washer
5	65050136	Hex. nut
6	65002457	Hex. Head screw
7	02400006	Guide roller
8	65051036	Self locking nut
10	65012443	Socket head screw
12	65003448	Hex. Head screw

**Fig. C Lip**

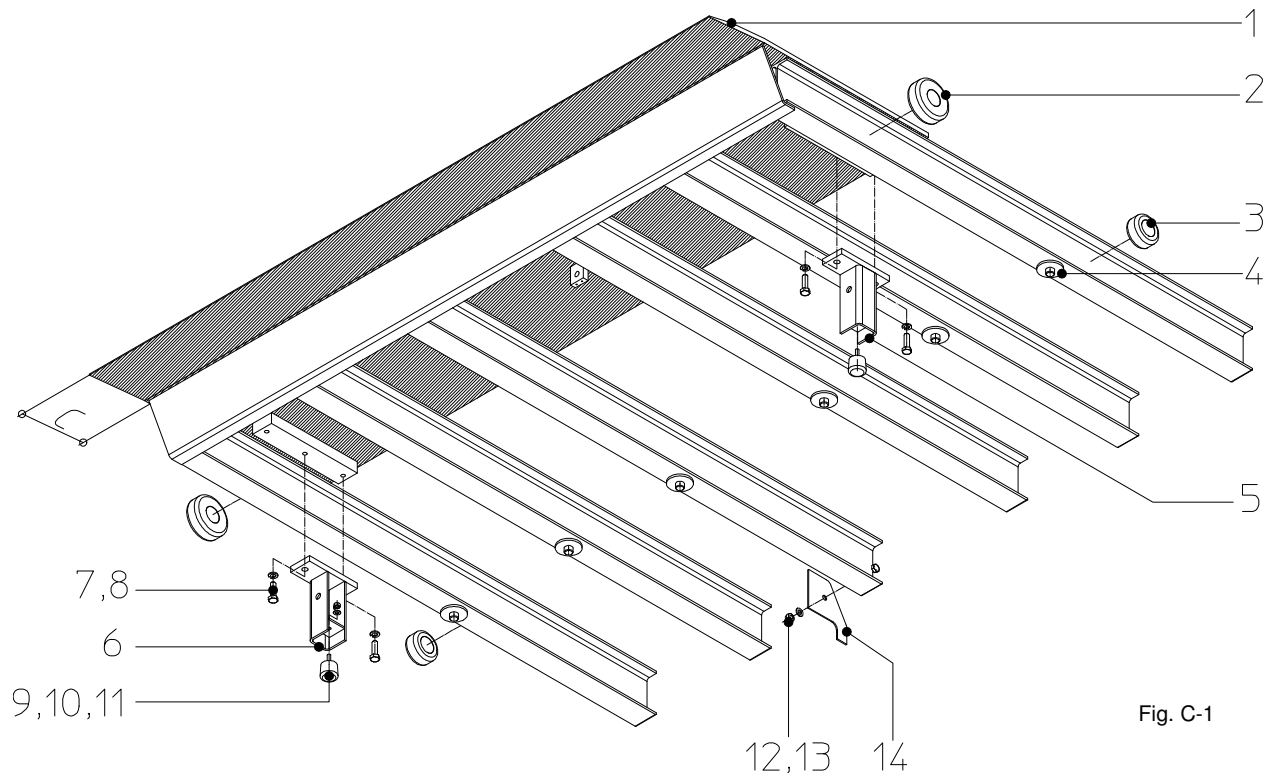

Fig. C-1

**Table C-1 Lip with standard clearance C = 175 mm (thread plate)**

Lip (1)				Guide roller front (2)	Guide roller rear (3)	Slide plate (4)
Width/Length	06	08*	10**			
XP..17	06000300	06010300	06020300	02400004	02400005	02600002
XP..18	06002300	06012300	06022300	02400004	02400005	02600002
XP..20	06004300	06014300	06024300	02400004	02400005	02600002
XP..21	06006300	06016300	06026300	02400004	02400005	02600002
XP..22	06008300	06018300	06028300	02400004	02400005	02600002

\* Only for models ..20 and ..22, \*\*Not for models ..20 and ..22

**Table C-2 Lip with extended clearance C = 350 mm (thread plate)**

Lip (1)				Guide roller front (2)	Guide roller rear (3)	Slide plate (4)
Width/Length	06	08*	10**			
XP..17	06000350	06010350	06020350	02404946	02404947	02400002
XP..18	06002350	06012350	06022350	02404946	02404947	02400002
XP..20	06004350	06014350	06024350	02404946	02404947	02400002
XP..21	06006350	06016350	06026350	02404946	02404947	02400002
XP..22	06008350	06018350	06028350	02404946	02404947	02400002

\* Only for models ..20 and ..22, \*\*Not for models ..20 and ..22

**Table C-3 Additional parts**

Index	Reference	Description
5	06200006	CTL A 20../22../25../28../30..
	06250011	CTL B 35../40../45..
6	06250006	CTL B 20../22../25../28../30..
	06200011	CTL A 35../40../45..
7	65058032	Spring washer
8	65003447	Hex head screw
9	65050132	Hex nut
10	1038060084	Washer
11	66201046	Rubber buffer CTL
12	65051034	Self locking nut (not with 08 lip)
13	66201046	Washer (not with 08 lip)
14	02603003	Safety hook (not with 08 lip)

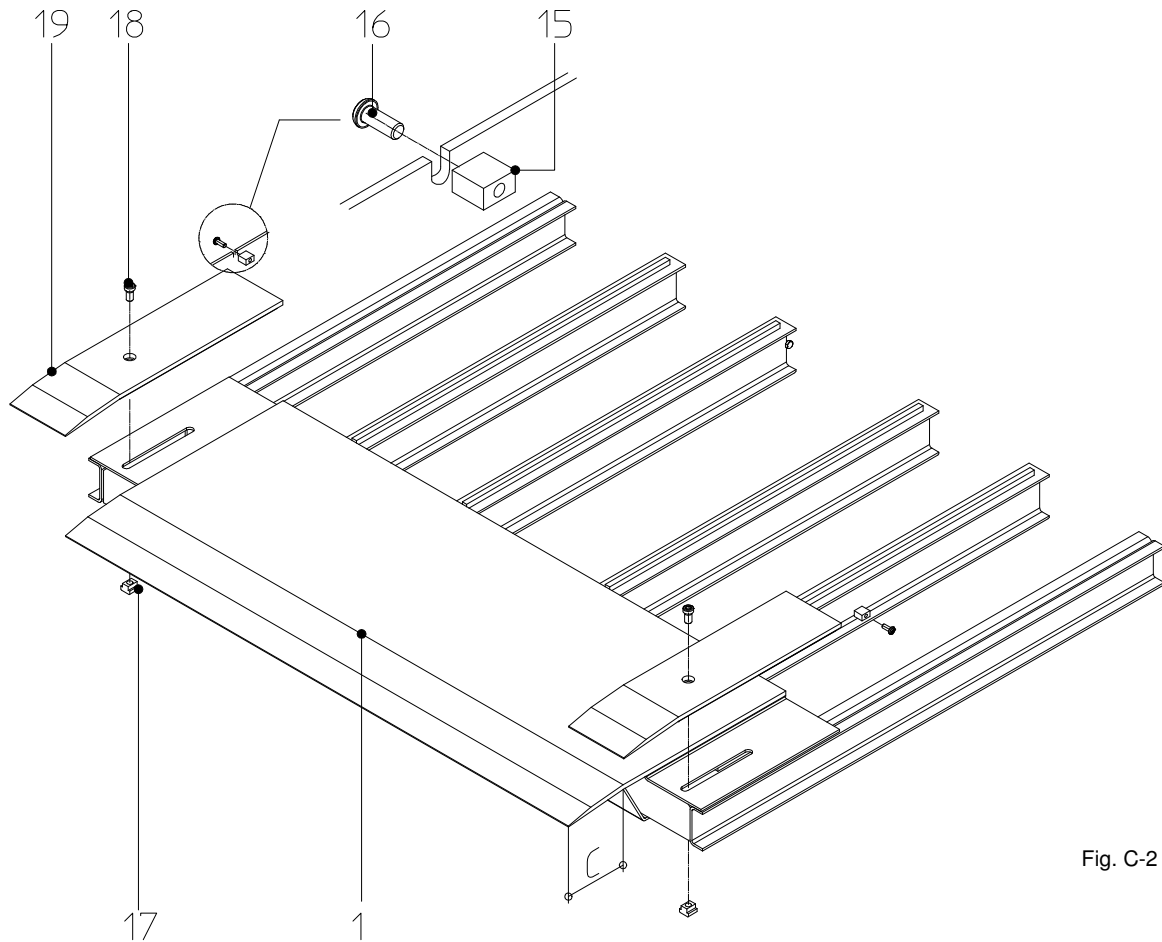

Fig. C-2

**Table C-4 Lip with standard clearance C = 175 mm and sections (thread plate)**

Lip (1)				Guide roller front (2) (see Fig. C-1)	Guide roller rear (3) (see Fig. C-1)	Slide plate (4) (see Fig. C-1)
Width	06	08*	10**			
XP ..20	06204325	06214325	06224325	02400005	02400005	02600002
XP ..21	06206325	06216325	06226325	02400005	02400005	02600002
XP ..22	06208325	06218325	06228325	02400005	02400005	02600002
Section (19)	06204340	06224340	06224340	-	-	-

\* Only for models ..20 and ..22, \*\*Not for models ..20 and ..22

**Table C-5 Lip with extended clearance C = 350 mm and sections (thread plate)**

Lip (1)				Guide roller front (2) (see Fig. C-1)	Guide roller rear (3) (see Fig. C-1)	Slide plate (4) (see Fig. C-1)
Width/Length	06	08*	10**			
XP ..20	06204375	06214375	06224375	02404948	02404947	02400002
XP ..21	06206375	06216375	06226375	02404948	02404947	02400002
XP ..22	06208375	06218375	06228375	02404948	02404947	02400002
Section (19)	06204390	06224390	06224390	-	-	-

\* Only for models ..20 and ..22, \*\*Not for models ..20 and ..22

**Table C-6 Additional parts**

Index	Reference	Description
15	02400001	Stop block
16	65025056	Button head screw
17	65225005	T-slot nut
18	65225004	Socket head screw

**Fig. D Hydraulic unit**

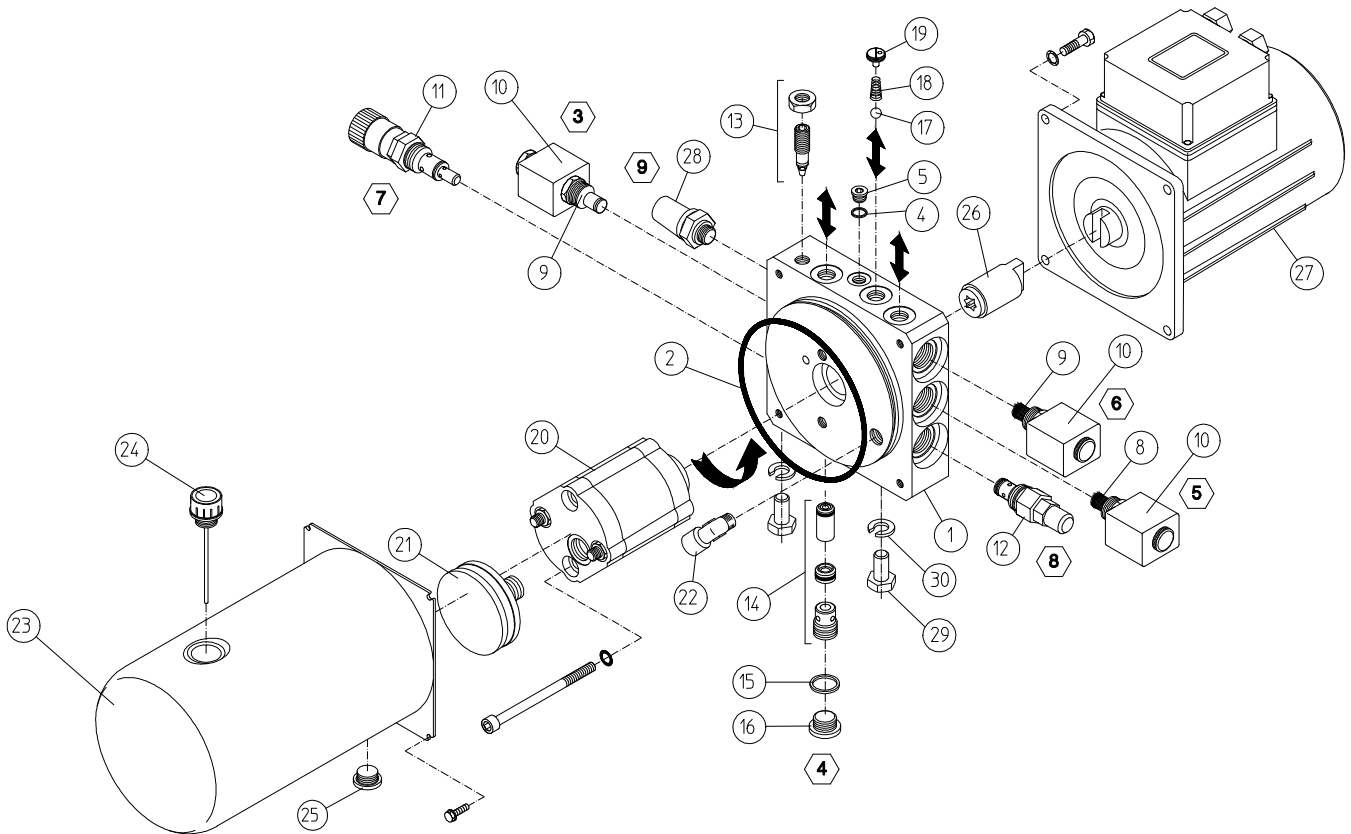

**Table D-1 Hydraulic unit**

Index	Reference	Description
-	02606600	Hydr. pump unit assy. 230/400V - 50 HZ
-	02606960	Hydr. pump unit assy. 200V - 50 HZ (Option)
-	02606965	Hydr. pump unit assy. 200V - 60 HZ (Option)
-	02606970	Hydr. pump unit assy. 230V - 60 HZ (Option)
2	02606602	O-Ring
8	68308013	2/2 Cartr. valve CEI-D-DT
9	68308014	2/2 Cartr. valve NC BI-DIR.
10	69481501	Solenoid
11	32006257	Main release valve
12	68208501	Lip release valve
13	68238501	Throttle
14	02335636	Logic valve
16	02600699	Plug (incl. pos. 15)
20	68113020	Hydr. pump 50 Hz
21	68821301	Suction filter
23	02606623	Tank
24	02335614	Filler/breather/dipstick
25	02335623	Drain plug
26	02606626	Coupling
27	02335611	Electric motor 230/400V - 50 Hz
28	69171019	Pressure switch
29	65003447	Hex head screw
30	65055021	Washer

**Fig. E Main cylinder**

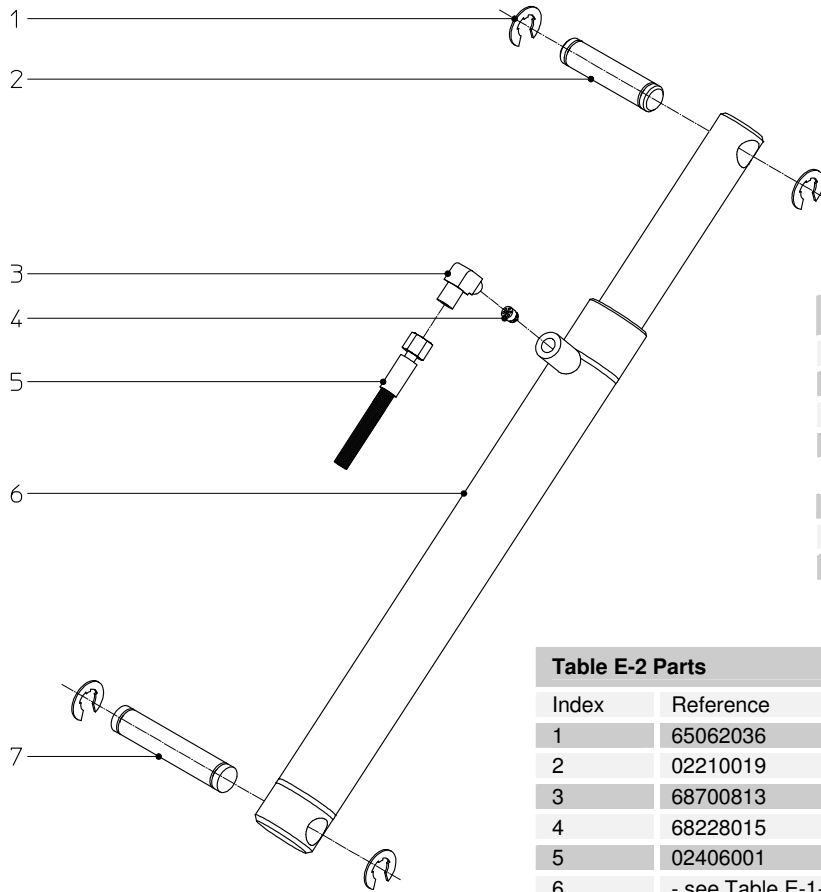

XP 20..	
XP 22..	06200625
XP 25..	
XP 28..	06230625
XP 30..	
XP 35..	06010625
XP 40..	06020625
XP 45..	

Index	Reference	Description
1	65062036	Retaining ring
2	02210019	Hinge pin (deck side)
3	68700813	Adaptor
4	68228015	Safety valve
5	02406001	Hydr. hose main cylinder
6	- see Table E-1-	Main cylinder (incl. 3 and 4)
7	01510021	Hinge pin (frame side)

**Fig. F Lip cylinder**

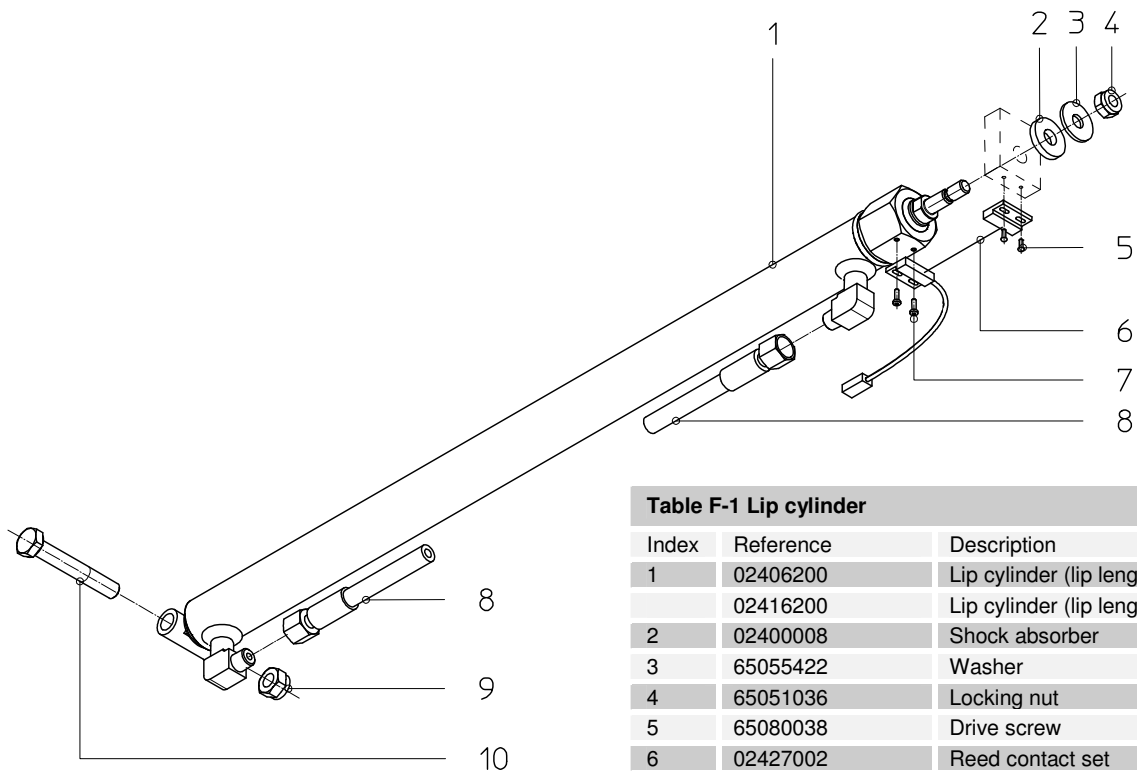

Index	Reference	Description
1	02406200	Lip cylinder (lip length 06)
	02416200	Lip cylinder (lip length 08/10)
2	02400008	Shock absorber
3	65055422	Washer
4	65051036	Locking nut
5	65080038	Drive screw
6	02427002	Reed contact set
7	65034167	Screw
8	02406002	Hose lip cylinder
9	65051034	Lock nut
10	65002457	Hex head screw

**Fig. G Control box - standard**

Table G-1 Control boxes - standard			
Standard	400V	230V	200V
	06200710	06000715	06200720

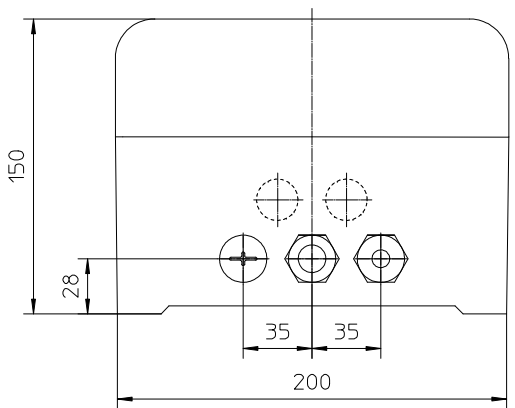
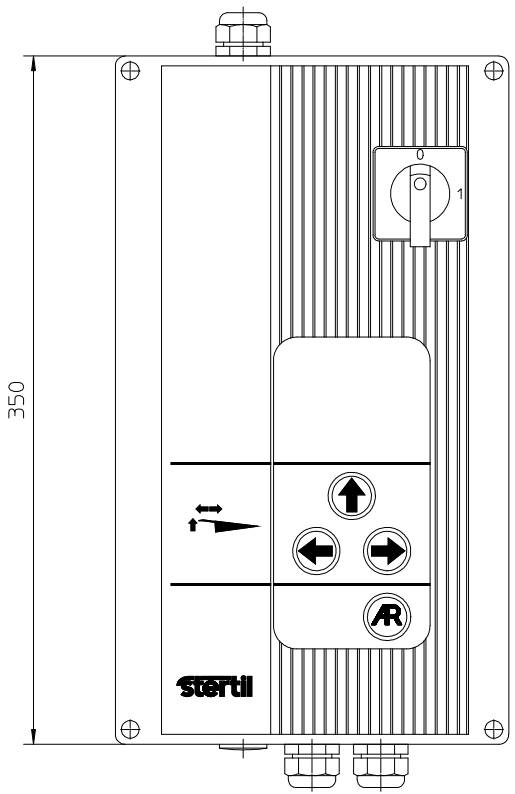
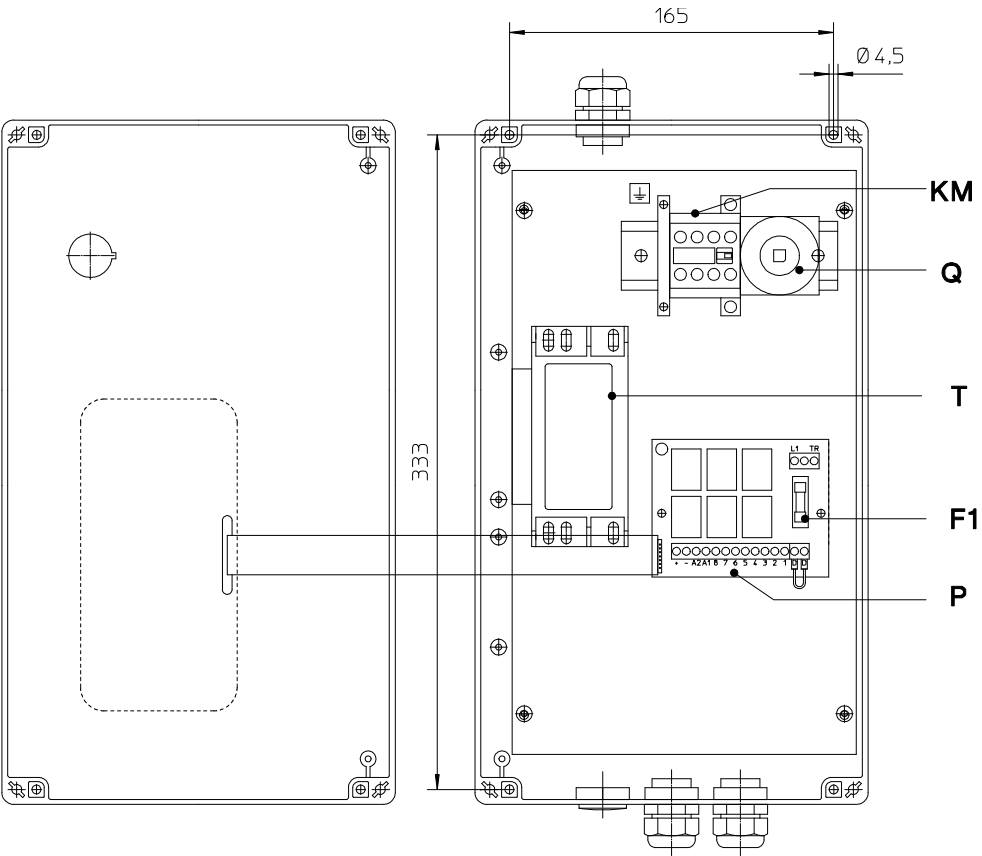

**Table G-2 Replacement parts**

Index	Reference	Description
Q	69120028	Main switch
KM	01615652	Magnetic switch
T	69500005	Transformer 400V
	69500006	Transformer 230V (optional)
	69500005	Transformer 200V (optional)
F1	69206006	Fuse 250mA slow
	69206007	Fuse 400mA slow (optional)
P	69900260	Printed circuit board
CM	01810763	Motor cable
CC	02407001	Control cable
CD	02407092	Cable branching